

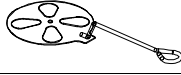

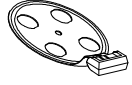







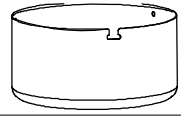



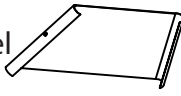
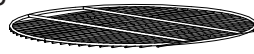



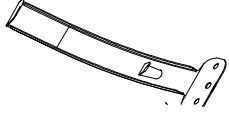
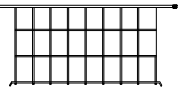

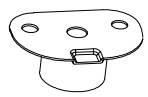
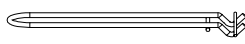



# Kettle Grill

## Product Parts

1	Handle		3pcs	11	Bowl Air Vent		1pc
2	Lid Vent		1pc	12	Air Vent Support		1pc
3	Temperature Gage		1pc	13	Ash Pan		1pc
4	Handle Connector		1pc	14	Ash Pan Handle		1pc
5	Lid		1pc	15	Imprinted Front Panel		1pc
6	Cooking Grate		1pc	16	Leg w/ Wheel		2pcs
7	Coal Grate		1pc	17	Support Leg		2pcs
8	Grate Support		4pcs	18	Wire Shelf		1pc
9	Bowl		1pc	19	Wheel & Wheel Cover		2pcs
10	Bowl-Leg Connector		4pcs	20	Grate Handling Tool		2pcs

A.	M6x12	  	16PCS	D.	M8	 	2PCS
B.	M5x12		2PCS	E.	M5x16		6PCS
C.	M4x20	 	3PCS	F.	M6x40	 	4PCS



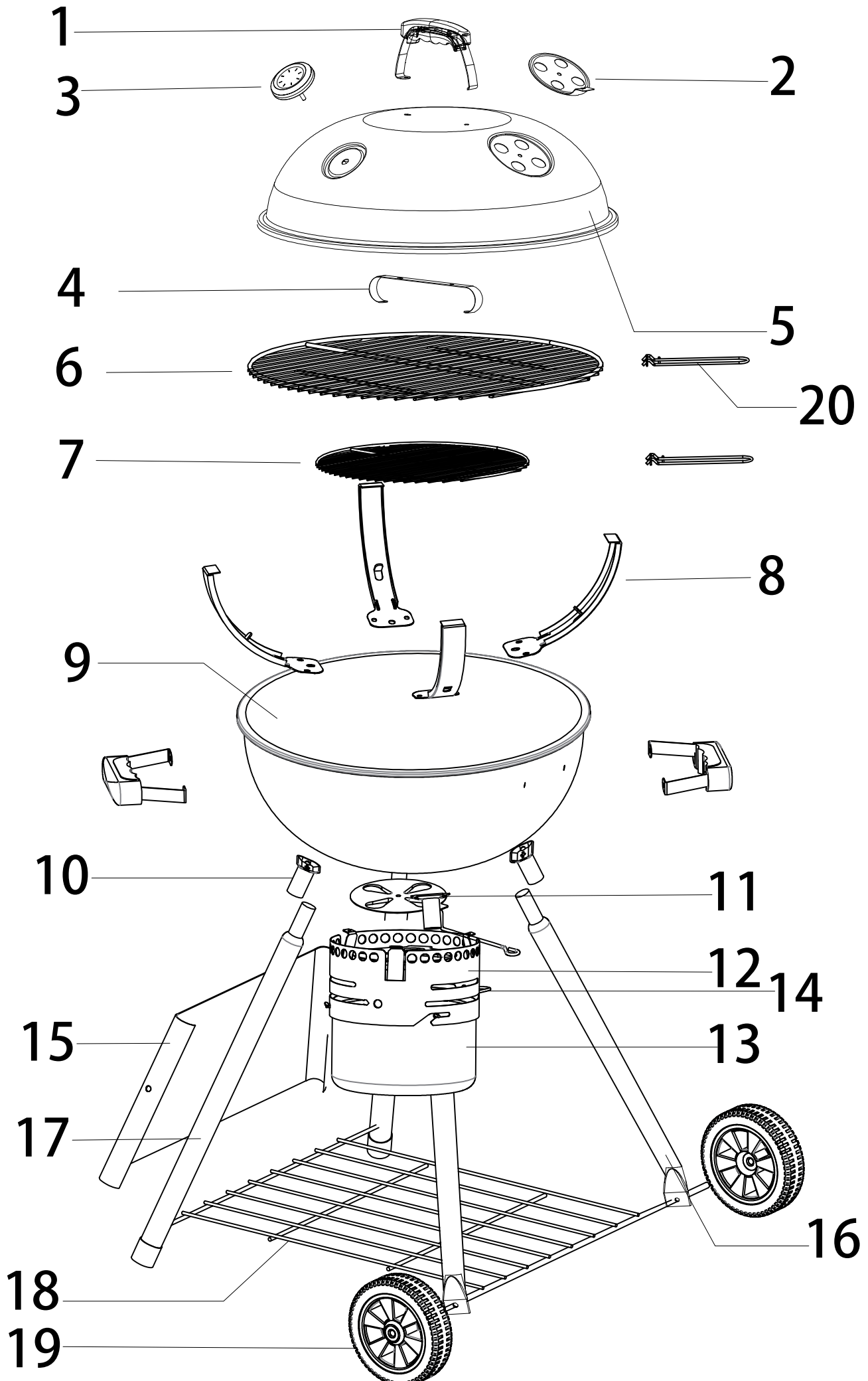

# Assembly

Tools: Phillips screwdriver  
 Use indicated, Screws, Nuts,  
 Bolts, and washers when assembling the Grill.

## Step 1 Assemble the 3 Handles.

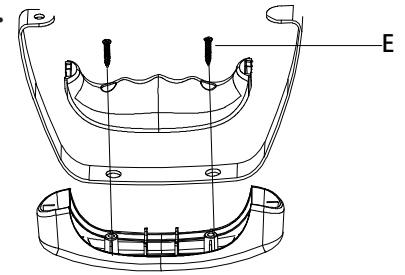

E. M5x16  6PCS

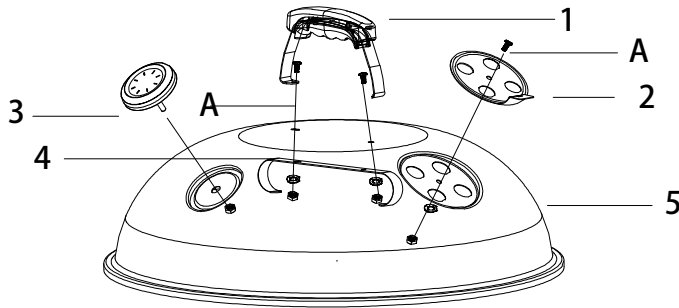

A. M6x12    3PCS

## Step 2 Assemble the Lid.

Add the Temperature Gage, Inner Lid Handle Connector with Lid Handle, and Lid Vent.

## Step 3 Add handles to the bowl.

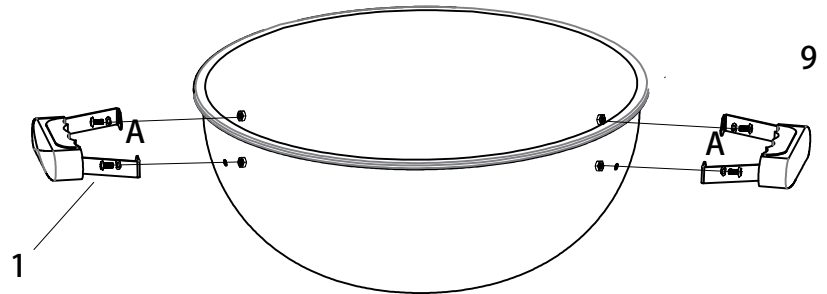

A. M6x12    4PCS

## Step 4 Insert Grate Support (8) to the inside of the Bowl and the Bowl-Leg Connectors (10) to the outside of the Bowl (9).

Attach the Leg w/ Wheel (16) to one side of the grill and the Support Legs (17) to the other.

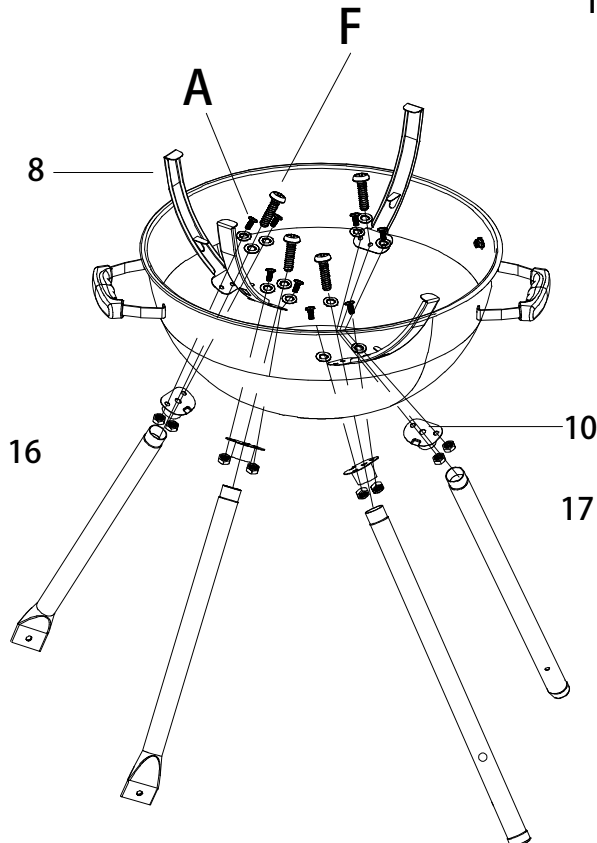

A. M6x12    8PCS

F. M6x40   4PCS

### Step 5

Add Bottom Wire Rack, Attaching the ends of the Wire Rack (18) to the indicated spots on the Legs (16 & 17).

Add the Wheels and Wheel Covers (19) to the Legs w/ Wheels (16).

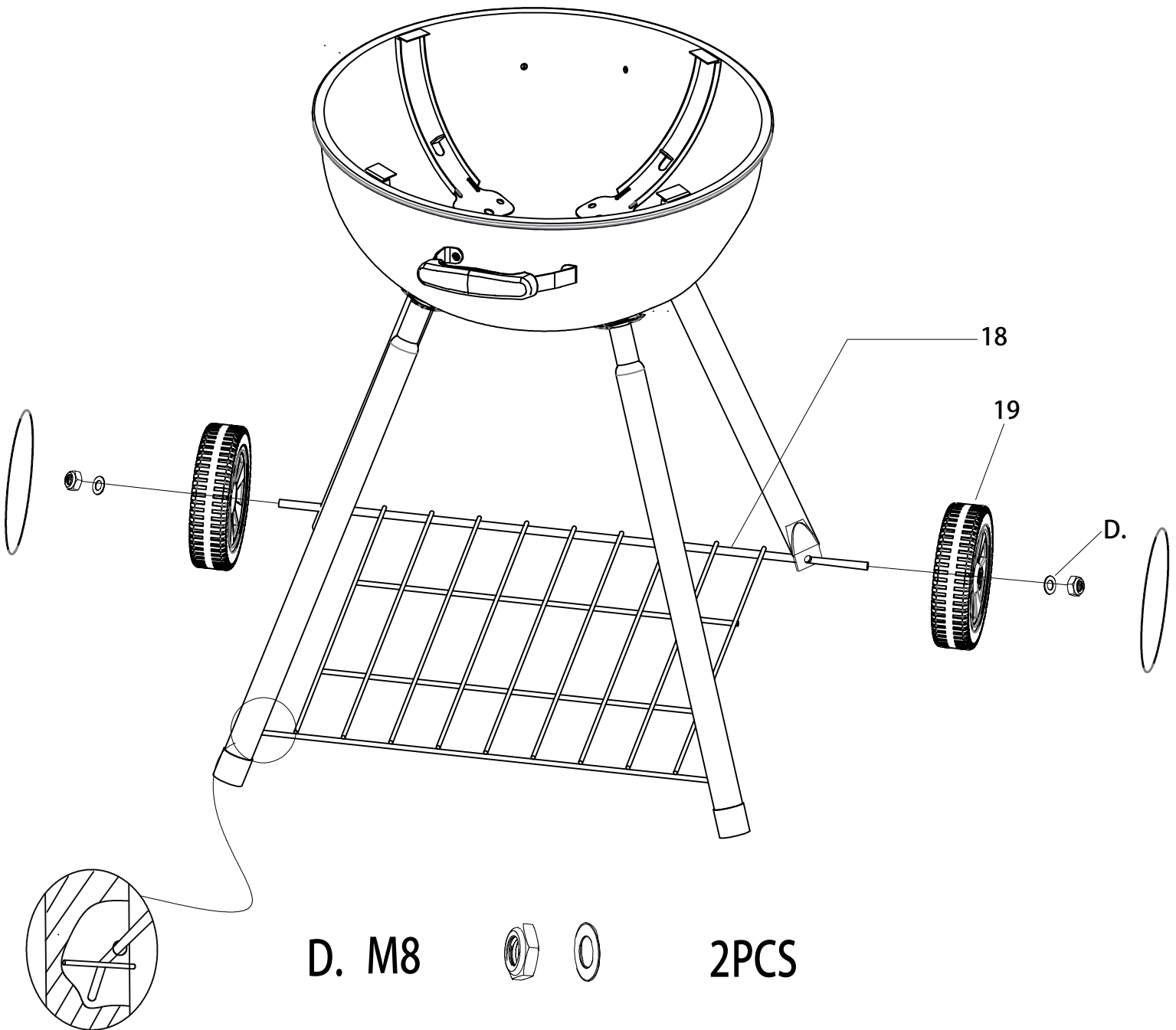

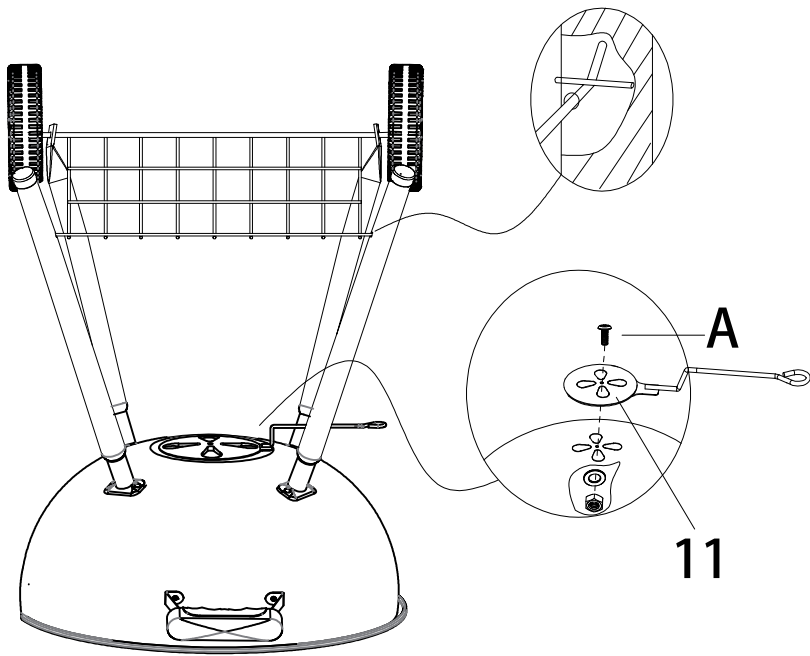

**Step 6**  
 Flip Grill over to add Bowl  
 Air Vent (11) and Air Vent  
 Ring Support (12).

A. M6x12  1PCS

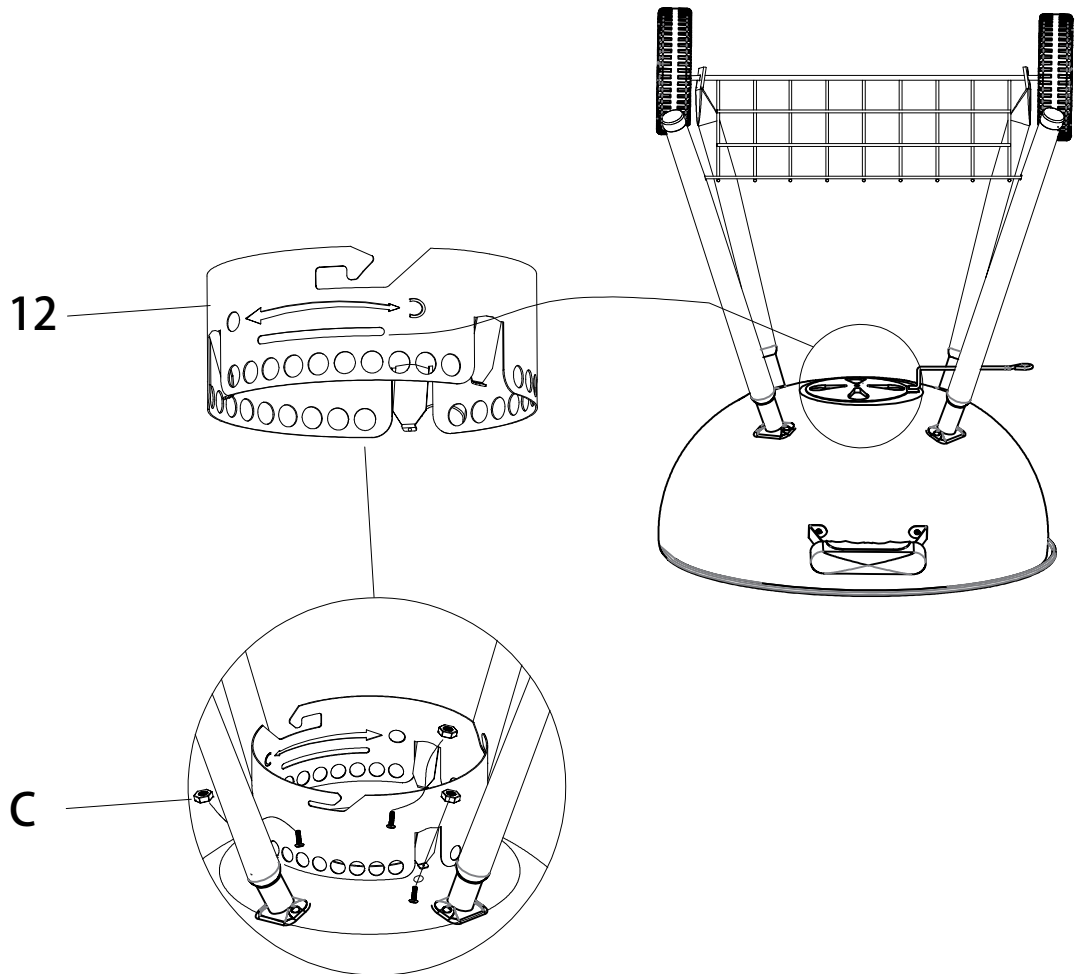

C. M4x20  3PCS

### Step 7

Slide the Ash Pan Handle (14) into the notch on the Ash Pan (13).

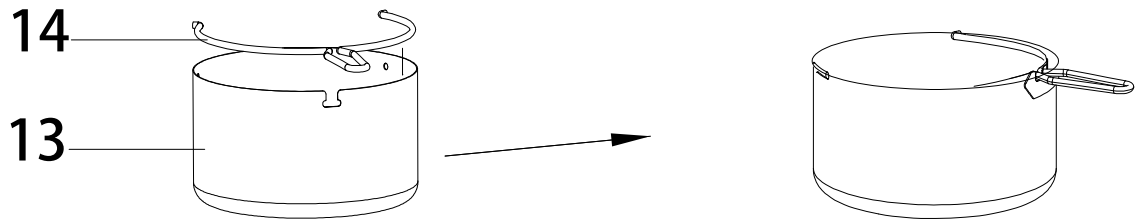

### Step 8

Add Charcoal Grate (7) and Cooking Grate (6).

Attach the Ash Pan (13) into the grooves on the Air Vent Ring Support (12).

Attach Imprinted Front Panel.

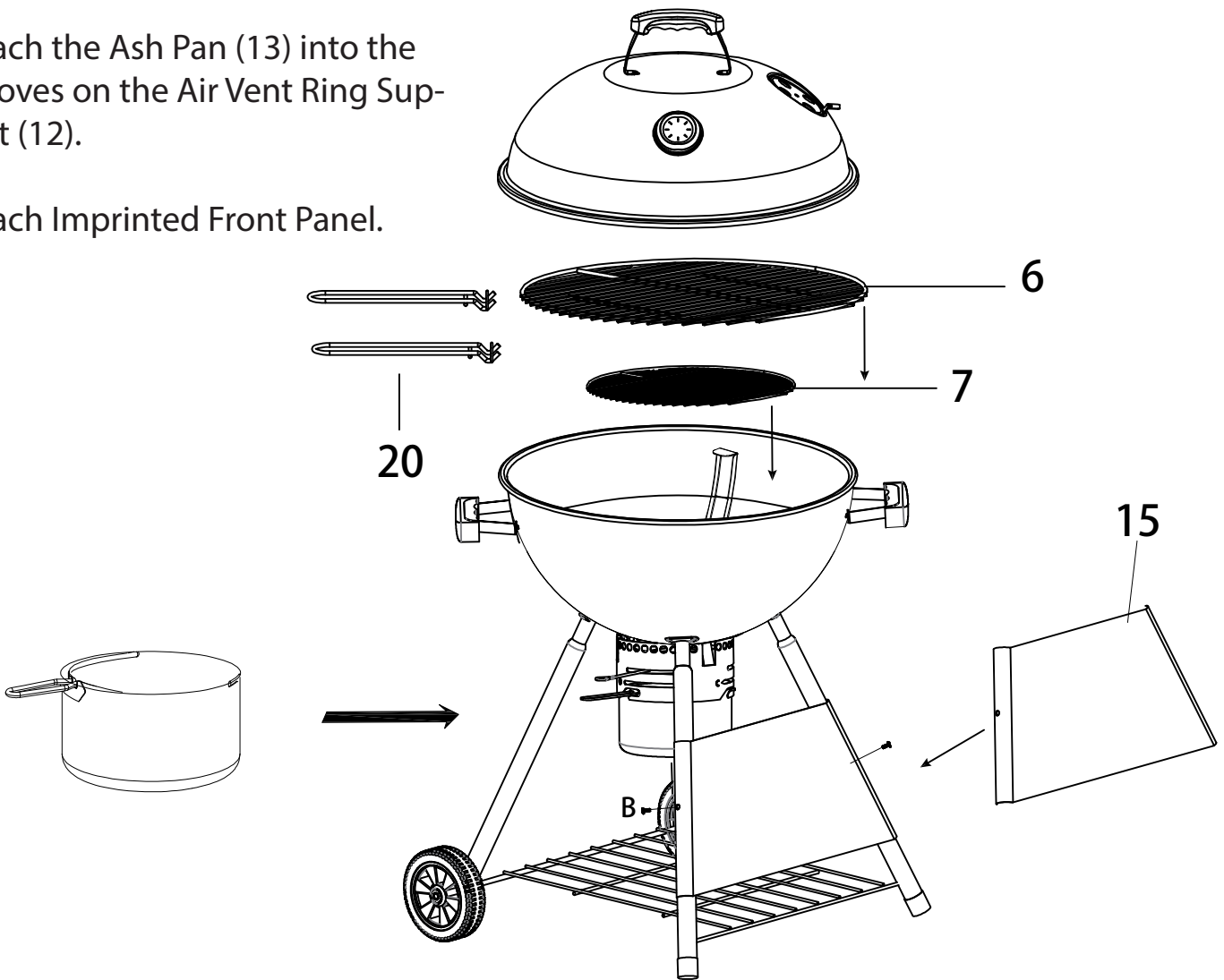

B. M5x12  2PCS